

EQStm

Six Channel Pre-Amp Equalizer
Owner's Enjoyment Manual

AudioControl[®]

making good stereo sound better[®]

22410 70th Avenue West • Mountlake Terrace, WA 98043 • Phone 425-775-8461 • Fax 425-778-3166

This page intentionally left blank.

Table Of Contents

Introduction.....	1
Features and Highlights.....	2
Quick Installation Information	4
A Guided Tour of the EQS	5
Installation	8
Placement and Mounting	8
Power Wiring	8
Audio Wiring	9
Level Matching	11
Equalization Adjustment	12
PFM Subsonic Filter	14
Troubleshooting	14
Warranty.....	15
Specifications.....	17

Introduction

Congratulations on your purchase of the EQS, the worlds first six channel pre-amp equalizer from AudioControl, the leading manufacturer of performance signal processors and analyzers. Whether this is your first product from the rainforest dwellers of AudioControl or you are already a firm believer, you will definitely enjoy how great the EQS can make your performance autosound system sound.

Now before you start salivating too much just thinking about the benefits of the EQS, take a few minutes to sit back, have a latte', decaffeinated if necessary, and read through this manual. It contains lots of useful facts and information -- and besides, we spent a lot of time writing it!

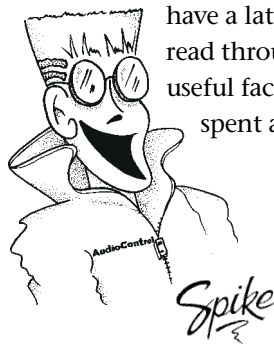

KEY FEATURES OF THE EQS

Here are some of the cool features that are enclosed in this magical box:

- Dual-bandwidth equalization
- 13 volt pre-amp line driver
- Auto Select™ Inputs
- Voltage indicator LED's
- Speaker level inputs
- PFM subsonic filter
- Balanced differential inputs

FEATURES AND HIGHLIGHTS

Dual-bandwidth Equalization: Car interiors vary widely in size and acoustic make-up. In addition doors, kick-panels, and rear decks don't make the best location for speaker placement causing your high performance speaker system to sound somewhat lackluster. The EQS offers maximum equalization controls for each area of the audio spectrum. One-third octave bass equalization combined with one-half and full octave high frequency equalization offers an ideal level of control.

13 Volt Pre-Amp Line Driver: The EQS offers a high quality line driver that takes the low output voltage of a source unit and increases it up to 18dB (13 volts peak). This allows you to maximize the signal-to-noise of your system and drive your amplifiers to their maximum output without clipping. No hiss, clicks, or pops plus maximum sound quality.

Auto Select™ Inputs: Whether your source unit has two, four, or six outputs, the EQS will automatically switch the inputs to maximize your equalization controls.

Speaker Level Inputs: If you are like many people and like the look and features of your factory installed source unit but feel it's lacking power and bass, we have good news. The EQS has a unique high impedance speaker level input that will interface with most factory installed source units (even Bose) and let you add amplifiers and speakers to your hearts content. However, unlike some of the cheesy speaker level line output converters available, the EQS offers a very high fidelity sound quality input.

PFM Subsonic Filter: This unique feature is legendary with many AudioControl fanatics for it's ability to fine-tune the bass response of any system. Why waste power on nasty subsonic information when your Programmable Frequency Match (PFM) filter will help you clean things up.

Bulletproof Warranty: The most important feature of all. Every AudioControl product is selflessly designed and manufactured by the occupants of our



rainforest factory. We take every effort to ensure that you will have many years of enjoyment out of your EQS. To ensure the performance of your new toy, we highly recommend that you allow your authorized AudioControl dealer to perform the installation. Not only do they have all the right knowledge and tools, but in the unlikely chance your EQS should stop working, we will back it with a limited five years parts and labor warranty. Should you choose to install it yourself we will still give you one-year parts and labor warranty. To activate your warranty, you need to **FILL OUT AND SEND IN YOUR WARRANTY CARD!**

We also recommend that you save your invoice or sales slip as proof of installation and ownership. Not only is it necessary for warranty purposes, but should your EQS "disappear" one day while your car is parked at your local latte' stand, you will find insurance companies very unfor-giving without proof of purchase.

QUICK INSTALLATION INFORMATION

For those of you short on time but high on ambition we offer the following section to speed up your installation of the EQS:

1. The EQS needs to be installed in the signal path between your source unit and an external amplifier(s). If this is not obvious to you, quickly pack up your EQS and run to your nearest authorized AudioControl dealer to have them perform the installation. You will thank us later.
2. Physically mount the EQS in a location that keeps it away from soda spills, food crumbs, and curious fingers. However you will want to select a location that allows you access to the equalization controls.
3. Hook up +12 volt power, -12 volt ground, and remote turn-on. If you need to know more, then read on. Heck if you don't think you need to

know more, you should still read on, because you can never know too much.

4. Level match the inputs of your EQS to your source and then adjust the outputs to match with your amplifier inputs.

Note: You will want to turn the gains on your amplifiers *DOWN* to maximize your systems performance.

5. Now comes the fun part. Set your equalization controls to where your system sounds the most balanced yet dynamic. More about this in the section titled "Adjusting Your Equalizer"...and you thought you would not have to read the rest on the manual. Hah!

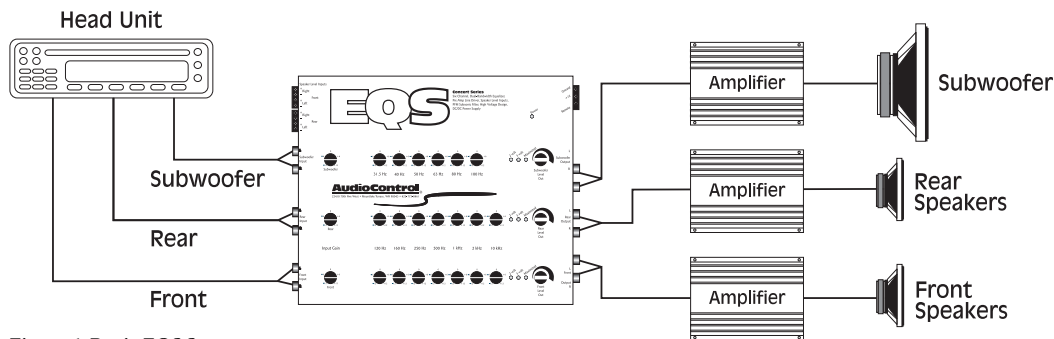

Figure 1: Basic EQS System

FACTORY SETTINGS

	Shipped	Options	Page #
PFM Subsonic Filter	33Hz	15Hz-63Hz	7
Input Grounding	Balanced	Unbalanced	7
Ground Isolation	Isolated	200ohm or Ground	7
Choice of beverage	Micro-brew	Latté	19

A GUIDED TOUR OF EQS

1. Inputs: The EQS has two types of inputs, PRE-AMP and SPEAKER LEVEL. These inputs should get their signals from the main source unit/head unit and should attach to either RCA jacks **or** speaker leads that are coming out of your source unit. If your source unit has a front, rear, and subwoofer pre-amp outputs, connect them to identical inputs on your EQS. If the source unit only has front and rear inputs, don't worry about losing your bass equalization, the Auto Mode™ circuitry in your EQS automatically routes your subwoofer equalization controls to the rear channels.

2. Input Gain Controls: These knobs allow you to increase or decrease the signal level from your source unit to the EQS. Most aftermarket source units will require an increase whereas radios installed by the automobile manufacturer will probably require you to decrease the signal level.

3. Equalization Controls: Each one of these nifty knobs is essentially a "tone" control dedicated to a specific part of the audio spectrum. They can be adjusted to help your speakers match with the "acoustical fingerprint" of your cars interior. In addition you can tweak them to coincide with your listening preference.

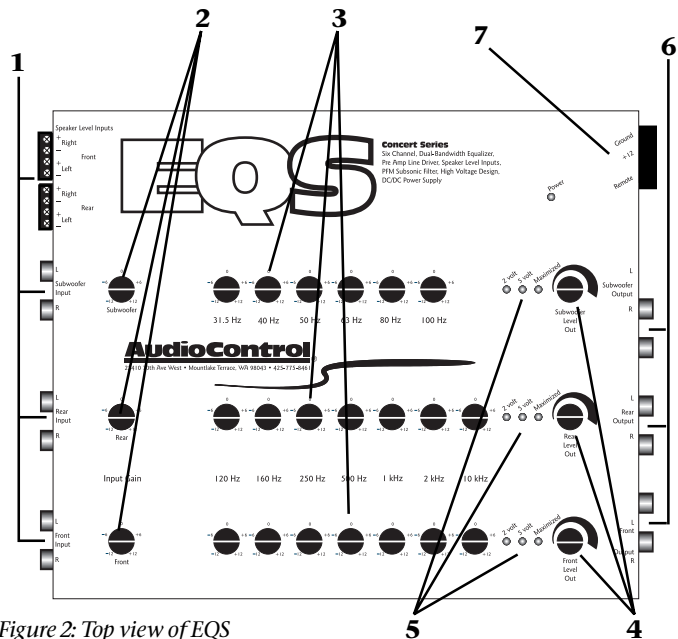

Figure 2: Top view of EQS

4. Output Level Controls: Although your EQS has the ability to increase your signal voltage to 13 volts peak, your amplifiers may not necessarily accept that much signal. These controls allow you to regulate the proper amount of pre-amp signal from the EQS to the amplifiers.

5. Output Voltage Indicators: These brightly colored LED's indicate the level of signal voltage that is coming out of the various outputs of your EQS.

6. Outputs: These RCA connectors should be connected to the next component after the EQS, such as a crossover or amplifier. Do not connect any speakers directly to your EQS or to any home appliances, like your toaster.

7. Power Connections: This nifty connector is a godsend to anyone who has tried to wire up their gear with their body crammed in the trunk. You can wire up the power, ground, and remote turn-on from the convenience and then casually plug it in the back of your EQS.

UNDER THE COVERS

1. Input Grounding: For most systems you can leave this jumper set in the BALANCED position. In some systems, the source unit may look for a ground through the RCA connection to the amplifier and create a ground loop, which in turn can cause a whine (we are not talking about Merlot) in your system. In that event, you should go ahead and change the four jumpers to the UNBALANCED position. In that event, you should go ahead and change the four jumpers to the UNBALANCED position.

2. Ground Isolation Selector: Occasionally alternator noise may appear in a system because the source unit and amplifier are using different grounding schemes. To help in this situation, we have provided alternative grounding connections. *Make sure your system is turned OFF before you move these jumpers.*

3. PFM Subsonic Filter: The EQS utilizes the world famous AudioControl, PFM (Programmable Frequency Match) filter to help with speaker control and amplifier power management. To change the PFM frequency, it is as simple as removing the cover and changing the module, which you will want to do when the power is disconnected. Your authorized AudioControl dealer carries an assortment of these modules.

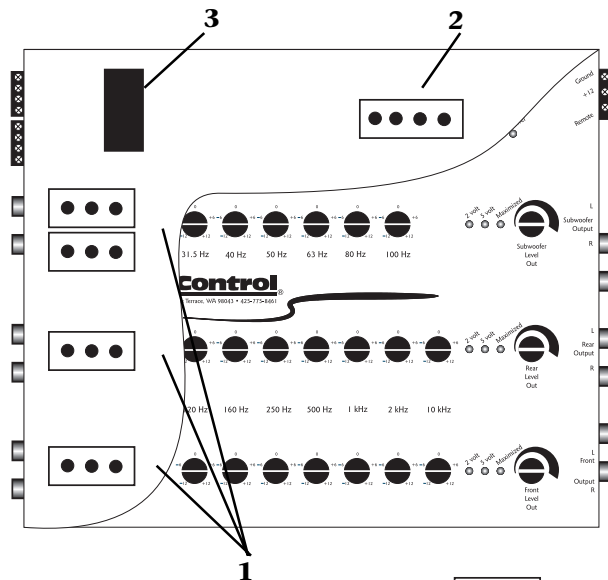
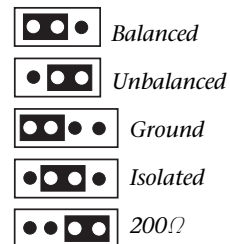

Figure 3: Cut away of inside of EQS (not to scale)



INSTALLING THE EQS

Up to this point everything you have read has served to educate you on the operations of EQS. We are sure that you are chomping at the bit to install EQS so we recommend you read the following sections very carefully.

A. Placement & Mounting Of EQS

Placement: The EQS needs to be installed in the signal path after your source unit but definitely before your amplifiers and or any active crossovers. The chassis is usually mounted in the rear of the vehicle close to the amplifiers as possible.

Mounting: Once you have selected a permanent mounting location, position the unit and mark the appropriate mounting holes with a felt-tip pin or scratch awl. Before doing anything else, make sure you are not about to drill a hole in a gas tank or piercing any existing wiring. Nothing ruins your day more than an expensive repair bill. Drill a few small pilot holes and secure the chassis of the EQS with self-tapping screws.

B. EQS Power Wiring

WARNING: Failure to disconnect the negative terminal of your battery prior to the installation of you EQS can result in a warm tingly feeling.

Remote Turn-On: Connect a 22 to 18 gauge wire from the head-unit's remote turn-on to the "Remote" connector on the EQS.

Positive(+12V) Connection: Insert a 12-18 gauge wire into the connector labeled "Power" on the nifty connector of your EQS. Connect it to a good constant source of 12 volts (we suggest the battery), fused at 2 amp.

Ground Connection: Use the same gauge wire as you did for the positive connector and run it from the "Ground" connector on the EQS to the negative terminal of the battery, a ground bus, or a verified ground location. ***The factory head unit ground is not a good ground!***

When the electrical connections are complete, you may reconnect the negative terminal to your battery.

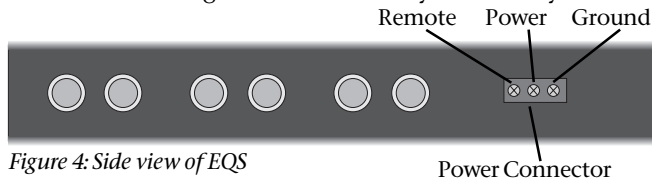

Figure 4: Side view of EQS

C. EQS Audio Wiring

Planning: As you may already have guessed, there are numerous ways to configure the EQS in your audio system. Spend a little quality time planning out your system and even sketching it out on paper. The following diagrams are just a few of the system options:

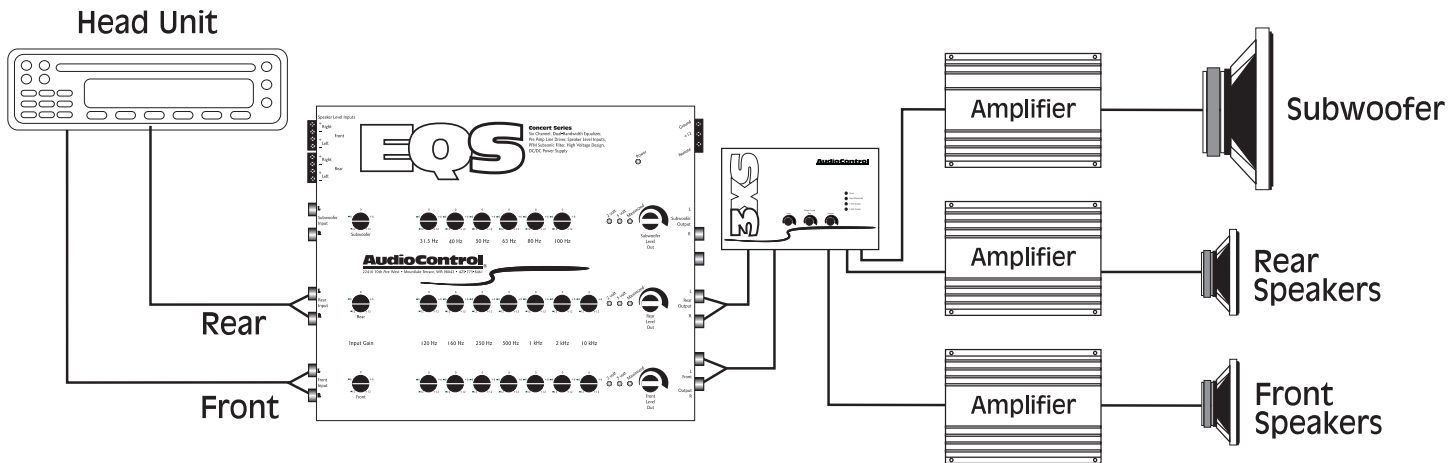

Figure 5: EQS with Four Channel Source Unit and 3XS crossover

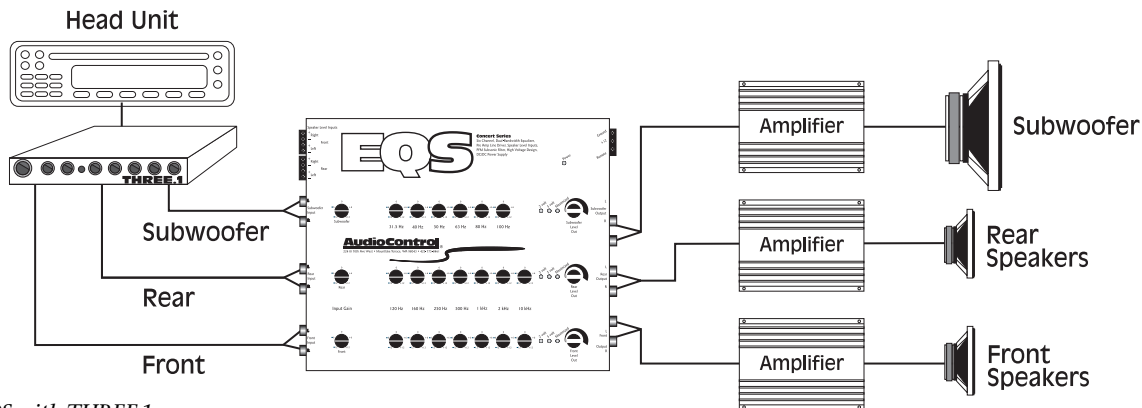

Figure 6: EQS with THREE.1

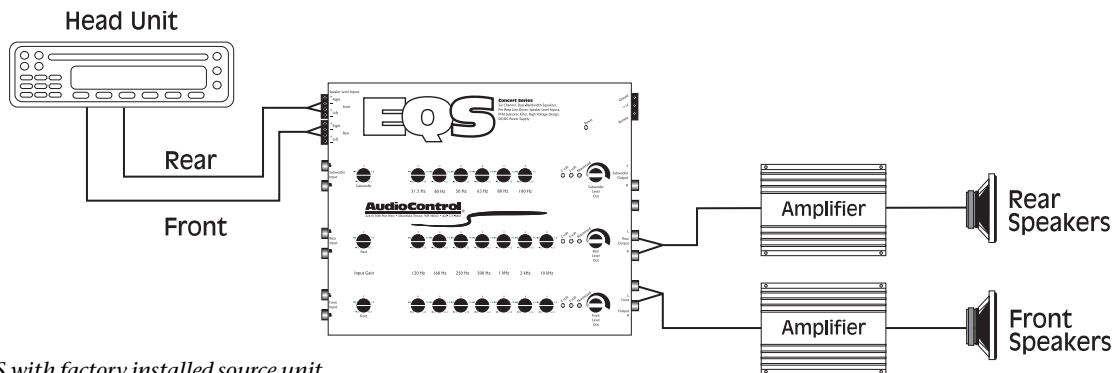

Figure 7: EQS with factory installed source unit

D. Level Matching

If you have ever listened to a friend's "killer" car audio system and heard lots of hiss, clicks or pops, then you have experienced an improperly level matched system. When a performance autosound system is properly level matched, you should get the maximum output from your source unit and amplifiers without any clipping or that annoying hiss! The following steps will help you through the process, although at the end of the day, your ears will be your guides!

1. Set your source units fader and balance controls to their center positions. If your source unit has subwoofer output (and you are using it), set the output level at minimum or "0".
2. Disconnect the connections between your EQS and the amplifier(s)...otherwise get some ear plugs.
3. Start playing some relatively dynamic music and set the volume on your source unit to about $\frac{3}{4}$ of maximum. You should not be hearing anything at this point. If you are hearing music, go back to step #2; if you are hearing voices go see a doctor!

4. Starting with the EQS "Front Input" gain control, increase or decrease the "Input Gain" control until the "Overload" LED begins to flicker steadily with the music. Do the same for the "Rear Input" and "Subwoofer Input".

• Important Note •

For Four Channel Or Speaker Level Input Users: If you are only using the "Front" and "Rear" **or** "Speaker Level" inputs, you will find that the subwoofer equalization now works on the rear channels. Therefore, the "Rear" input gain is actually controlled by the "Subwoofer" input gain control.

5. Now adjust the output level control until the "2 volt" or "5 volt" light starts to flicker. You will set the output voltage to match up with your amplifiers input gain levels. If you don't know how much this is, ASK the amplifier manufacturer or read the owners manual of the amplifier.
6. Very Important - Set the input gains on the amplifier(s) at minimum!
7. Double check that you performed Step #6
8. Decrease the volume control on your source unit and re-connect the RCA's between the EQS and the amplifier(s).

9. Now increase the volume on your source unit to your normal listening level. For some of you, this may be louder than others!

10. At this point you may find yourself going back and adjusting the “Output Level” controls on your EQS to balance the front, rear, and subwoofer sections of your system to accommodate for the speaker placement and efficiency. Speakers on the rear deck of your car will probably sound louder than the ones in your doors!

E. Equalization Adjustment

When it comes to music, everyone has his or her own particular taste. Some people want pounding bass and crisp, blood curdling highs. Others may prefer a “flat” response (whatever the heck that is). At the end of the day, most people just want their system to sound balanced and “just like it did in the store” or similar to their buddy’s car. The following equalization guidelines should help you achieve your own personal audio nirvana.

1. For optimum performance, get your hands on a test compact disc that contains pink noise and a good quality RTA (real time analyzer); we happen to know someone who

makes a really good one. If you cannot locate an RTA, you probably want to have your authorized AudioControl dealer perform the equalization adjustments as they will have one. You can certainly adjust your EQS using your ears, however an RTA will give you the best results.

2. Begin playing pink noise through your system and place the microphone for your analyzer on a microphone stand in the drivers seat. Take a careful look at the “curve” on your analyzer and how one frequency combines with the next.

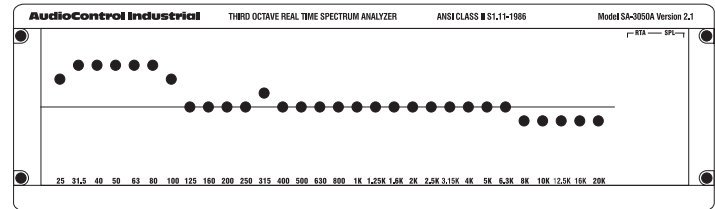

Figure 8: Sample Curve

There is no one curve that will satisfy every person, as we all have different tastes.

How else can you explain Liberace or rice cakes? The key is to use your EQS to help balance your system from one frequency to the next and give your speakers the sparkle, sizzle, detail or punch that the acoustics of the car have compromised.

3. You will want to start equalizing by removing or cutting any large bumps, peaks, or areas with too much energy at a particular frequency. Next, boost the ranges that do not have enough energy. We strongly recommend that you *cut* or *decrease* energy before you boost.

4. Although the plethora of knobs on your EQS can be intimidating, fear not as they were designed to give enough control to maximize your systems performance but not enough to get you in trouble. Here is an explanation of the key areas you should focus on:

Sub-bass: 100 Hz and below - A car without bass is like a day without sunshine... unless you live where we do because most of the days in the Pacific Northwest do not have sunshine. This area is one of the more critical although

it is also one of the most difficult to properly reproduce. Most people refer their bass frequencies to be 6 to 9 dB louder than the rest of their system, although there are some crazy folks that prefer their bass substantially louder. The key in this area is to have enough speakers and power to produce the amount of bass you desire but don't use the controls on the EQS to try and force your speakers to produce sounds they can't. Too much bass boost creates a condition called "speakerus explodus", which is not pretty to hear or watch.

Midbass: 100 Hz to 300Hz - The phrase, "too much of a good thing" can certainly apply to the midbass frequencies. This is the transition area of the audio spectrum that is an octave above your sub-bass frequencies and several octaves below your midrange. Most autosound systems have *too much* midbass due to the fact that speakers mounted in the doors or kick panels cause resonance's or peaks in the response curve. These peaks in the midbass can actually mask or block sounds in the all-important midrange area causing your system to sound dull or lifeless.

Midrange: 300Hz to 3Khz - Musical instruments, vocals, mid-range percussion and many things we associate with imaging and staging happen in this area of the band-

width. For that reason you will want to keep this area as smooth and balanced as possible. Too much boosting can make you feel like your listening to your system in a tile bathroom. Not enough energy midrange sounds empty and dry.

Treble: 3KHz and Up - If midrange is the cake, then these high or upper frequencies are considered the frosting. Many autosound systems start a gradual decline in this area which is why speaker placement is very important. The EQS only gives you a few controls in this area because too much boosting can really make a speaker sound un-natural.

F. PFM Subsonic Filter

Many car audio systems truly push the limits of their subwoofer...without really knowing it. Tuned enclosures affect the roll-off of many speakers, yet lots of source material forces the speakers to play lower than expected. The net result is **wasted** amplifier power and **damaged** speakers. The AudioControl PFM (Programmable Frequency Match or Pure F#@&% Magic) filter is a programmable subsonic filter. It allows you to only let the speaker play as low as it should be playing. Because every system is different, we allow you to change the PFM roll-off frequency to whatever you choose.

On most systems, the factory-installed module (33Hz) is fine. However, if you know the tuning frequency of your speaker enclosure (porting frequency or 3dB down point), you might try setting your PFM module to that frequency. If you want to protect your speaker system even more, you might even try a higher frequency as it will probably sound better than you think.

G. Troubleshooting

No Power: If the Power LED on your EQS will not turn on, check to make sure that the power wire and remote turn on wires are connected or a fuse has not blown.

Sounds Distorted: Should your system sound distorted or your speakers are moving way too much, you should make sure you have your levels matched properly and that your amplifier gains are set at minimum. If this checks out okay, you **will want to look at your EQ controls to insure that your boost levels are not too high.**

Still Sounds Distorted: Set the PFM filter higher to match your speakers response.

Output Voltage LED's Don't Light Up: If your system is playing music but none of the output LED's are on, there is a good chance that the output voltage of your source unit is not that high. Now before you call us say, "The guy at the store said my radio has high-voltage outputs", you might want to face the fact that there is "Engineering Voltage" and there is "Marketing Voltage". Without picking on any particular source unit, remember that you do get what you pay for.

IF YOU LIKE EQS, YOU'LL LOVE...

The **THREE.1** is the perfect in-dash equalizer for those of you who like the sound and detail of the EQS but want to have some control of your system from the dash of your car. Of course you should not be driving while tweaking your **THREE.1**, but enjoy it nevertheless.

If you need a crossover for your system that keeps up with your **EQS**, the **3XS™** is a 4 channel, 2-way crossover with breathtakingly steep 24dB per octave slopes. If performance is important to you, then you will appreciate the **3XS**. Of course if you are just looking for deeper, breath-taking bass, than **The Epicenter** our patented (U.S. patent # 4,698,842) bass restoration processor is just the hot ticket. It puts the woof back in your woofers!

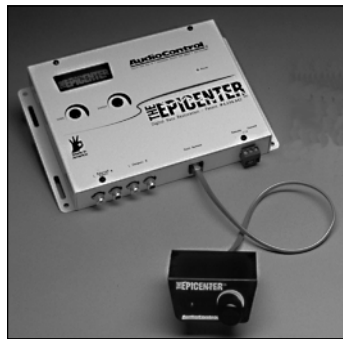
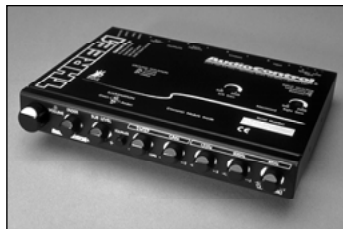

And now a word from the legal department...

THE WARRANTY

People are scared of warranties. Lots of fine print. Months of waiting around. Well, fear no more, this warranty is designed to make you rave about us to your friends. It's a warranty that looks out for you and helps you resist the temptation to have your friend, "...who's good with electronics", try to repair your AudioControl product. So go ahead, read this warranty, and then take a few days to enjoy EQS before sending in the warranty card and comments.

"Conditional" doesn't mean anything ominous. The Federal Trade Commission tells all manufacturers to use the term to indicate that certain conditions have to be met before they'll honor the warranty. If you meet all of these conditions, we will warrant all materials and workmanship on your EQS for one year from the date you bought it (five years if it is installed by an authorized United States AudioControl dealer). We will fix or replace it, at our option, during that time.

Here are the conditional conditions:

1. You have to fill out the warranty card and send it to us within 15 days after purchasing your EQS.
2. You must keep your sales receipt for proof of purchase, showing when and from whom the unit was bought. We're not the only ones who require this, so it's a good habit to get into with any major purchase.
3. Your EQS must have originally been purchased from an authorized AudioControl dealer. You do not have to be the original owner, but you do need a copy of the original sales slip.
4. You cannot let anybody who isn't (A) the AudioControl factory; (B) somebody authorized in writing by AudioControl to service your EQS. If anyone other than (A) or (B) messes with your EQS, that voids your warranty.
5. The warranty is also void if the serial number is **altered or removed**, or if EQS has been used improperly. Now that sounds like a big loophole, but here is all we mean by it.

Unwarranted abuse is (A) physical damage (don't use the EQS for a jack stand); (B) improper connections (120 volts into the power jack can fry the poor thing); (C) sadistic things.

This is the best mobile product we know how to build, but if you mount it to the front bumper of your car, something will go wrong.

6. If an authorized United States AudioControl dealer installs your EQS, the warranty is five years, otherwise the warranty is one year.

Assuming you conform to 1 through 6, and it really isn't all that hard to do, we get the option of fixing your old unit or replacing it with a new one.

LEGALESE SECTION

This is the only warranty given by AudioControl. This warranty gives you specific legal rights that vary from state to state. Promises of how well the EQS will perform are not implied by this warranty. Other than what we have covered in this warranty, we have no obligation, express or implied. Also, we will not be obligated for direct or indirect consequential damage to your system caused by hooking up the EQS.

Failure to send in a properly completed warranty card negates any service claims.

EQS SPECIFICATIONS

All specifications are measured at 14.4 VDC (standard automotive voltage). As technology advances, AudioControl reserves the right to continuously change our specifications, like our Pacific Northwest weather...although we *are* working on it.

Maximum input level	15 V _{rms}
Maximum speaker level input	100 watts
Maximum output level	13.5 V _{peak}
Input gain	18 dB
Frequency response	10Hz-100kHz; ± 1dB
Total harmonic distortion	0.003%
Signal to Noise ratio	- 110dB
Balanced input noise rejection	60dB
Input Impedance	20 Kohms
Output Impedance	150 Ohms
Equalization Cut/Boost	± 12 dB
Power supply	High headroom PWM switching
Power draw	500mA
Recommended fuse rating	2 Amp
Size	8.8" W x 9.3"D x 1.3"H
Weight	3.25 lbs

Not affiliated with Microsoft, Starbucks or other seattle area companies — at least not today.

AudioControl, Making Good Stereo Sound Better, EQS, The Epicenter, EQL, AutoMode and EQX are all trademarks of Electronic Engineering and Manufacturing, Inc.

This manual was conceived, designed, and written on several bleak, windy, and dreary rain-drenched days at our home in the Pacific Northwest Rainforest. The latte's were hot and the Heffeweizen's were cold...like our weather.

AudioControl®

making good stereo sound better®

22410 70th Avenue West
Mountlake Terrace, WA 98043 USA
425-775-8461 • Fax 425-778-3166
www.audiocontrol.com

© 2001, AudioControl, a division of Electronic Engineering and Manufacturing, Inc. All rights reserved

P/N 9130640